

Crio Smart 2 Door Digital Refrigerator, 1430lt (-2/+10) - Remote

ITEM # _____

MODEL # _____

NAME # _____

SIS # _____

AIA # _____



729053 (ARX142FRR)

2-door refrigerator
1430L, -2+10°C, digital, AISI
304, remote

Short Form Specification

Item No. _____

Two full doors refrigerator with internal and external structure in 304 AISI stainless steel; external back panel in galvanized steel and bottom panel in anti-corrosive material. Digital control with cabinet temperature display and setting and manual activation of defrost cycle. Fully compliant HACCP digital controls include visible alarms. Optimized back to front forced air flow provides even temperature distribution and fast cooling in any conditions. Fitted with 75 mm-thick cyclopentane insulating foam. Door features lock and door microswitch to switch off the fan when the door is opened. Hidden evaporator to guarantee higher storage capacity and less corrosion problems. Remote refrigeration unit; ventilated operation; automatic defrost and evaporation of defrost water. For ambient temperatures up to 43 °C. CFC and HCFC free. R134a gas in refrigeration circuit. Supplied with n. 6x2/1GN Rilsan coated grids and n. 6 sets of 2 stainless steel grid runners.

Main Features

- Automatic defrost.
- Large storage area suitable to contain 2/1 GN grids or shelves on anti-tilt runners.
- Operating temperature can be adjusted from -2 to +10 °C to suit different food storage requirements.
- Two full doors.
- Cabinet fitted with up to 75 mm thickness of cyclopentane insulation for best insulating performance with 100% environmental protection (thermal conductivity: 0,020 W/m*K).
- Hidden evaporator thus guaranteeing higher storage capacity and less corrosion problems.
- Internal structure with numerous charging positions available to host grids, ensuring higher net capacity and a greater storage space.
- 60 mm-thick insulation covering the evaporator can be easily removed with a single operation.
- Removable triple-chamber balloon magnetic gasket to improve insulation and reduce energy consumption and ease of cleaning.
- Rilsan coated grids for improved protection.
- Optimized back to front forced air flow provide even temperature distribution and fast cooling in any conditions.
- Digital control with cabinet temperature display and setting and manual activation of defrost cycle. Fully compliant HACCP digital controls include visible alarms.
- Connectivity ready for real time access to connected appliances from remote and data monitoring (requires optional accessory).

APPROVAL: _____

Construction

- Constructed from the highest quality AISI 304 Stainless steel.
- Interior base with rounded corners, pressed from a single sheet.
- Stainless steel runners and supports easily disassembled.
- Anti-corrosion bottom avoids any damage that may be caused to the cabinet by aggressive detergents employed to clean the floors.
- Easy access to the main components for maintenance.
- Lockable door.
- Door switch stops the fan when door is opened to avoid cold air exiting the cell, thus saving energy.
- Refrigerant type: R134a.
- CFC and HCFC-free insulation.
- Doors are self-closing and can be fully opened up to 180°.
- Mounted on adjustable Stainless steel feet, with castors as an option.
- Remote refrigeration unit.
- The rounded internal corners, the easily removable runners and grids allow for ease of cleaning and high hygiene standards.

Included Accessories

- 6 of 2/1GN gray rilsan grid with 2 runners PNC 881020

Optional Accessories

- Remote unit -2/+10°C for 1430L refrigerated cabinets (R134a) PNC 880232
- 2 stainless steel runners for refrigerated cabinets - (Marine) PNC 880242
- 1/1GN set of 8 PVC containers for fish PNC 880243
- Spacer for 670L and 1430L refrigerated cabinets PNC 880248
- Kit integrated HACCP for digital refrigerators (IR33) PNC 880252
- Kit to fit 20 pastry trays (400x600mm) PNC 880333
- Plastic container with false bottom, 1/1GN PNC 880705
- 2/1GN gray rilsan grid PNC 881004
- AISI 304 stainless steel grid, 2/1GN PNC 881016
- AISI 304 stainless steel grid with 2 runners, 2/1GN PNC 881018
- Meat rail for 670/1430L refrigerators with 4 hooks PNC 881019
- 2/1GN gray rilsan grid with 2 runners PNC 881020
- Pedal opening for 1430L refrigerators PNC 881033
- PVC container with lid and 2 runners, 2/1GN PNC 881039
- 2/1GN perforated shelf PNC 881042
- 1/1GN rilsan steel wire basket h150mm PNC 881043
- 3 gray rilsan central grids for 1430L (not for glass door) PNC 881044
- 2/1GN gray rilsan basket + 2 runners h150mm PNC 881047
- 5 swivelling wheels (2 with brake), diam 125mm, for 1430 lt refrigerators, NOT for remote models PNC 881294
- KIT HACCP EKIS PNC 922166

Front

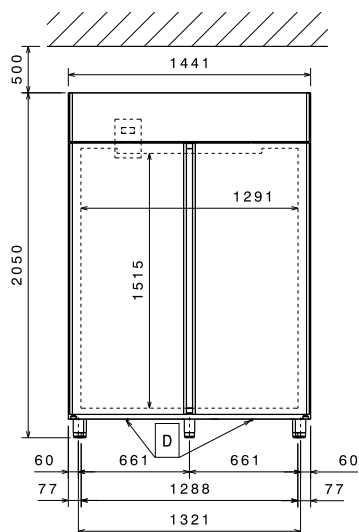

Side

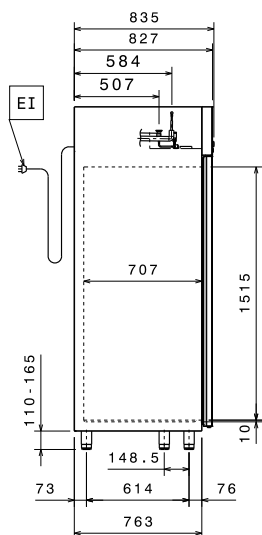

EI = Electrical inlet (power)
RI = Refrigerant Inlet
RO = Refrigerant Outlet

Top

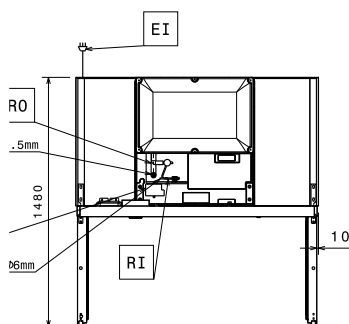

Electric

Supply voltage:	729053 (ARX142FRR)	220-240 V/1 ph/50/60 Hz
Electrical power max.:		0.305 kW
Defrost Power:		0.2 kW
Current consumption:		1.32 Amps
Plug type:		CE-SCHUKO
Energy consumption (min,default):		0 - 0 kW/h

Key Information:

Gross capacity:	1430 lt
Net Volume:	1005 lt
Door hinges:	1 Left+1 Right
External dimensions, Width:	1441 mm
External dimensions, Depth:	835 mm
External dimensions, Height:	2050 mm
Number and type of doors:	2 Full
Internal Dimensions, Width:	1291 mm
Internal Dimensions, Depth:	707 mm
Internal Dimensions, Height:	1515 mm
Net weight:	165 kg
Shipping volume:	2.82 m ³
Height adjustment:	0/0 mm
Number and type of grids (included):	6 - GN 2/1

Refrigeration Data

Control type:	Digital
Compressor power:	
GWP Index:	1430
Refrigeration power:	458 W
Refrigeration power at evaporation temperature:	-10 °C
Refrigerant weight:	0 g
Min/Max internal humidity:	
Operating temperature min.:	-2 °C
Operating temperature max.:	10 °C
Refrigeration type:	R134a;R513A;R426A
Operating mode:	Ventilated
Suggested refrigeration power:	458 W
Condition at evaporation temperature:	-10 °C
Condition at condensation temperature:	55 °C
Condition at ambient temperature:	43 °C
Connection pipes (remote) - outlet:	9.5 mm
Connection pipes (remote) - inlet:	6 mm

Product Information (EU Regulation 2015/1094)

Crio Smart
2 Door Digital Refrigerator, 1430lt (-2/+10) - Remote

The company reserves the right to make modifications to the products without prior notice. All information correct at time of printing.

Energy Class:

Yearly and daily energy consumption:

Climate class:

Energy Efficiency Index (EEI):